



KS-AMP POWER CO., LTD.



www.ks-app.com

Turn Waste to Power





The background knowledge of waste heat

In some industries, such as petrochemical, steel, paper-making...etc., there is a lot of hot water, steam or gas generated in production process. Usually, all these heat resources will be discharged or cooled. It is not only polluting the atmosphere but also waste the latent heat...

Fossil fuel reserves depleted rapidly. There are many concerns about nuclear safety. How to use renewable energy, such as geothermal, biomass, solar energy source effectively?

High-pressure transmit and low-pressure use is the key features of steam. It mostly equips PRV in use site if there is heat demand in following process. However, the energy loss of the pressure is also the economic loss...

Today, these waste heat sources are all useful for screw expander generator. The screw expander provides a renewable power solution by converting low, medium and high temperature heat into electrical energy. It can achieve energy saving and environment protection. Undoubtedly, it is an efficient, clean and reliable way to achieve energy saving and environment protection.



Company Briefing



Global Focus Local Service

Kerry® is a famous brand name for screw and centrifugal compressor products. With a group of over 30 years' experience experts and engineers, Kerry delivers extraordinary solutions for screw expander and its product are made in China by KAISHAN.

KAISHAN Group was founded in 1956, is the biggest air compressor manufacturer in Asia, and NO.3 in the world. KAISHAN specially developed rotor profile (Y shape line) for screw expander, which can refine, improve and promote the performance as well as the cost efficient in the use of KAISHAN screw expanders.

Since 1994, AMPOWER has been a premier supplier for power system, from emergency diesel generator to

independent development PLTC™ System, which is a synchronizing system for utility and generators. With on-site engineering experiences and professional team, AMPOWER configure the ideal power system solutions to every application and earn customers' appreciation.

We based on Kerry® Kaishan excellent screw expander technology as well as AMPOWER experienced turnkey solutions in power system, offering customers in Asia Pacific solutions from planning, production, installation to service. We not only fulfill customers to earn economic benefits by turning waste heat to power, but also devote in contribution to green earth by reduction of waste heat emission to environment.



① Isentropic Efficiency More than 70%

Kerry® Kaishan screw expander can reach up to 70% and higher. The isentropic efficiency of the general small/medium turbine in using saturated steam as well as other expanders modified from compressor technology is about 55%. It means Kerry® Kaishan screw expander generate more 30% power. The isentropic efficiency of Kerry® ORC screw expander power plant is even up to 85%~88%.



Advantages about Kerry® Kaishan screw expander technology



② Avoids "Water Impact" damage with higher reliability

When saturated steam is expanded, steam carrying liquid and gas, the small water drops will hit the blade at high speed, which we call "Water Impact". Our steam screw expander use screw instead of impeller to avoid water impact damage, which substantially enhance in reliability.

③ Fits any potential waste heat

Kerry® Kaishan screw expander is able to recover and generate power from a broad range of thermal heat sources, including superheated steam, saturated steam, wet steam, hot water and other hot liquids. Steam turbine has difficulty to use the saturated steam flow rate of 2-3t/h to generate power. However, Kerry® Kaishan screw expander has overcome such short-coming.

④ Excellent performance of varying duties

Kerry® Kaishan screw expander can work well in unstable/fluctuating heat sources condition compared with the steam turbine. It is the best advantage of Kaishan screw expander.

⑤ Lower infrastructure and overall costs

Initial and overall cost for Kerry® Kaishan screw expander is lower. It can be installed in outdoor with small foundation. However, steam turbine has to be installed in inside building with bigger foundation and infrastructure.

⑥ Operation Wise

Kerry® Kaishan screw expander operate easily unattended, concurrently reduce the operation cost. In comparison, steam turbine needs at least a small team to monitor and operate.

⑦ The most important - Kerry® Kaishan screw expander can work in series to achieve higher efficiency

The most important is Kerry® Kaishan screw expander generator can work in series to achieve higher efficiency in according to customer conditions. For example, steam expander uses the pressure difference while ORC uses the latent heat of vaporization to generate power.



Kerry® Kaishan STEAM screw expander can accept pressure range from 0.15~2.5MPa(G). Single STEAM screw expander can generate 3MW electricity power with 48t/h saturated steam.



STEAM SCREW EXPANDER GENERATOR



Working Principle

Steam screw expander converts the heat into power using "Thermodynamics" working principle. Steam (saturated, superheated or wet steam) act as media for expander. While high pressure steam (point1) enters the expander, it pushes and turns the rotor. The rotor will drive the generator to generate power, and then reduce the temperature and pressure of steam (point2).

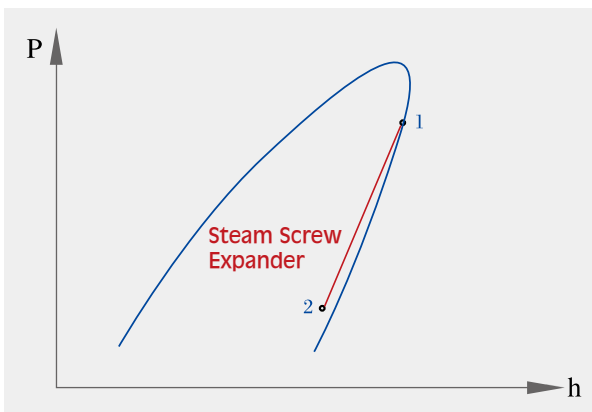

The exhaust low pressure steam can still be REUSED in the following process:

- Low pressure STEAM screw expander generator.
- ORC screw expander ORC power plant.
- User can use this steam in their manufacturing process.

Kerry® Kaisan STEAM screw expander working conditions:

Saturated or superheated vapor, wet steam with pressures higher than 1.5bar(G)

The steam screw expander is open-loop type. During the periods when steam enters to exhaust, the quantity of the steam will be maintained and the same quantity can be used for the next step in the process line.

Energy which lost of PRV in the past can be converted to power by steam screw expander now. There are two types: Back pressure and Condensing type can be chosen. The choice depends on following process heat requirements.



The ORC screw expander uses the organic actuating medium to absorb heat from heat source. The heated organic actuating medium expands in the work cell to push the rotors moving in circles and the male rotor provides the shaft power. The working condition's requirement is low which is more suitable for low grade heat.



ORC Screw Expander Power Plant



ORC principles

Evaporator absorbs heat and heats the medium to hot vapor (not steam). Then the medium enters the expander to turn the rotors to produce shaft power, then associates with its temperature and pressure reduction. Once the medium vapor exits from expander, it will enter a condenser to be converted into liquid and then pumped to the evaporator again.

Application conditions:

- Hot water above 80°C
- Other liquid above 80°C, for example oil, chemical material...etc
- Saturated steam, superheated steam, wet steam
- Exhaust gas (converted to thermal medium oil, hot water or vapor)

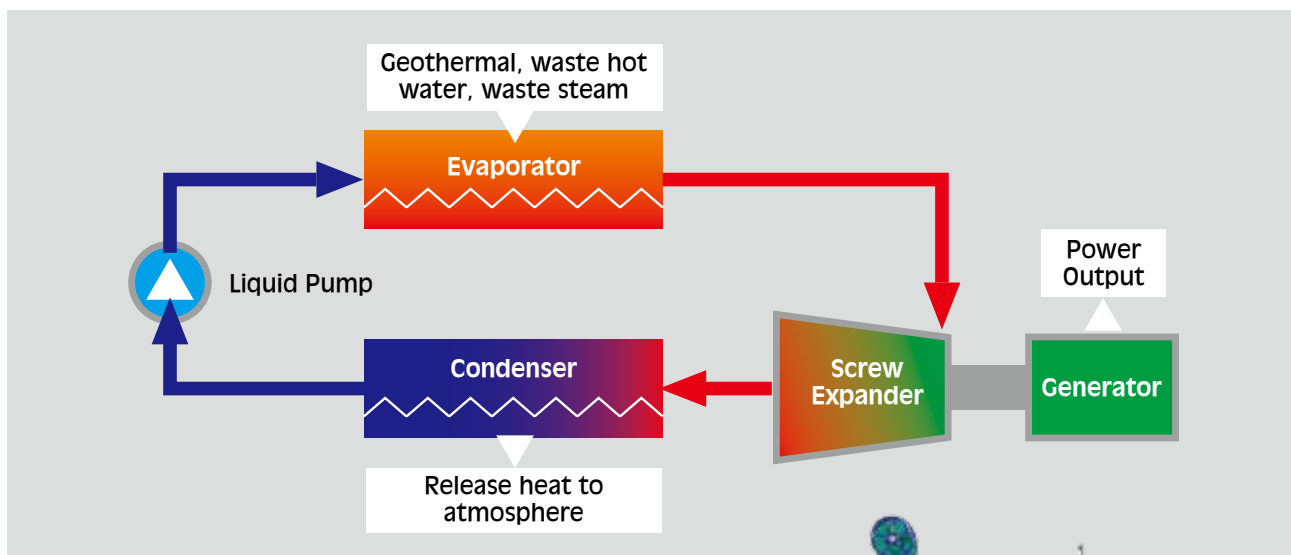

It is of extreme importance to have the right working medium chosen, which will influence such factors as the efficiency of power generation, specifications of equipment and the cost of construction etc. We have experienced the best working medium is R245fa.



To add 2nd stage design to achieve additional higher efficiency

According to different waste heat characters, Kerry® Kaishan screw expander can work in series with second stage screw expander. For example, steam expander use the pressure difference while ORC use the latent heat of vaporization to generate

power, whereas condensation of steam in Steam Turbine waste the latent heat easily by using cooling treatment with power consumption.

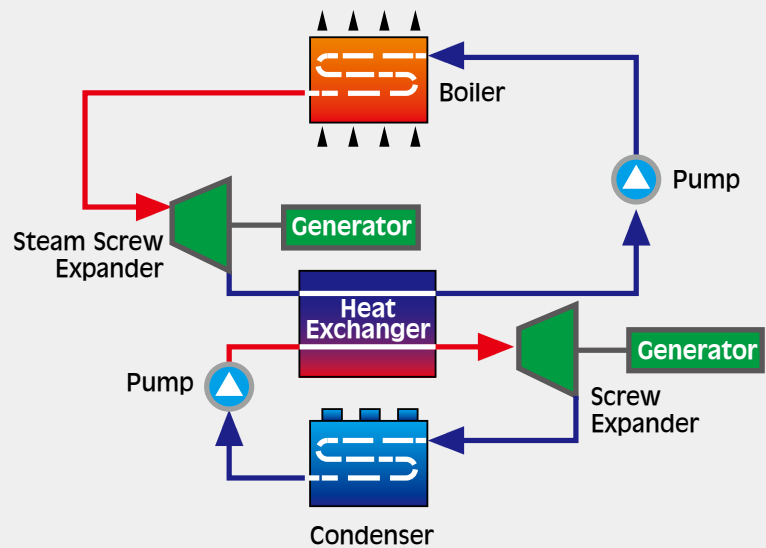

Reference Cases



Youfa Group Tianjina Tianfeng Stell Co., Ltd.

The waste steam condition:

Their converter generate saturated steam at 9.5t/h, 0.44MPa(A), exhaust at 1.08bar(A) steam to ORC screw expander.



Total Benefits

- Net output 839kW
- Annual output $8,000 \times 839 = 6,712,000$ kW
- Annual Production
 $6,712,000 \times 0.12 = 805.44$ K US dollars
- Annual CO₂ discharge reduction
 $6,712,000 \times 0.522 = 3,504$ Ton

* Average working hour is 8,000 hours.

* The electricity price is US\$ 0.12/KWh.

* To generate 1 KWh power discharge 0.522kg CO₂ (The Bureau of Energy of Taiwan, 2013)

Sinopec Hainan Oil Refining and Chemical is the first application in the world - two ORC plant working in series with the hot water as the heat source. They supply of hot water flow rate is 200t/h with 118°C temperature. The installation output of first part is 1,300kW. It can generate 4.63 kWh per ton water under ambient temperature 24.9°C, and the net power generation is up to 70%.

Kerry® ORC screw expander power plant

Working in series		High temperature	Low temperature	Total Benefits
Evaporating temperature		101°C	81°C	
Installed power		710 kW	630 kW	
Voltage Sepc		6,300 V	6,300 V	
Net Output	Ambient temp 34°C	438 kW	351 kW	789 kW
	Ambient temp 24.9°C	503 kW	424 kW	927 kW
	Ambient temp 15.5°C	544 kW	478 kW	1,022 kW

*34°C is the hottest month average temperature, 24.9°C is the annual average temperature, 15.5°C is the coolest month average temperature

Sinopec Hainan Oil Refining and Chemical Hot Water Application



Working in series		High temperature	Low temperature	Total Benefits
Annual Output	Ambient temp 34°C	3,504,000 kW	2,808,000 kW	6,312,000 kW
	Ambient temp 24.9°C	4,024,000 kW	3,392,000 kW	7,416,000 kW
	Ambient temp 15.5°C	4,352,000 kW	3,824,000 kW	8,176,000 kW
Annual Production	Ambient temp 34°C	420.48 K	336.96 K	757.44 K
	Ambient temp 24.9°C	482.88 K	407.04 K	889.92 K
	Ambient temp 15.5°C	522.24 K	458.88 K	981.12 K
Annual CO₂ discharge reduction	Ambient temp 34°C	1829 Ton	1466 Ton	3295 Ton
	Ambient temp 24.9°C	2100 Ton	1771 Ton	3871 Ton
	Ambient temp 15.5°C	2272 Ton	1996 Ton	4268 Ton
Net Generation Per ton Water	Ambient temp 34°C	3.95 kWh		
	Ambient temp 24.9°C	4.63 kWh		
	Ambient temp 15.5°C	5.10 kWh		
* Average working hour is 8,000 hours.				
* The electricity price is US\$ 0.12/KWh.				
* To generate 1 KWh power discharge 0.522kg CO ₂ (The Bureau of Energy of Taiwan, 2013)				



New Mexico Geothermal Application

New Mexico is well-known by using wind and solar energy, but those kinds of renewable energy has an intermittent problem which unable to provide uninterrupted power...

Unlike wind and solar power, geothermal runs 24/7 uninterrupted. Simply put, it's hot water pumped from reservoirs hundreds of feet below the ground. Heat from the earth's core warms up the water to temperatures up to 300°F (149°C). That water helps produce electricity. That same water is then re-injected into the underground reservoirs, so the water is continuously recycled.

Lightning Dock Geothermal (LDG) power plant is the first of its kind right in the state and it can produce up to 4 megawatts of

energy, which is enough to power 4,000 homes. In the near future, the plant will be capable to provide electricity up to 10,000 homes in New Mexico.

Power Benefits

- Output 4,000kW
- Annual Output
 $8,000 \times 4,000 = 32,000,000 \text{ kW}$
- Annual Production
 $32,000,000 \times 0.2 = 6,400 \text{ K US dollars}$
- Annual CO₂ discharge reduction
 $32,000,000 \times 0.522 = 16,704 \text{ Ton}$

* Average working hour is 8,000 hours.

* The electricity price is US\$ 0.2/KWh.

* To generate 1 KWh power discharge 0.522kg CO₂ (The Bureau of Energy of Taiwan, 2013)



Geothermal, New Mexico



Geothermal, Alaska



Zhejiang Yuanli Steel Group

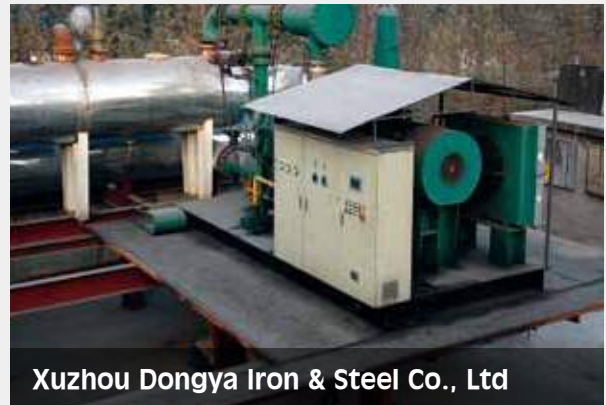

Xuzhou Dongya Iron & Steel Co., Ltd



Carnauba Oil Refinery, Philippines



HeNan Yaxin Steel Group Co., Ltd

Philippines carnauba oil refinery

The steam boiler generate saturated steam at 15t/h, 22Bar(G), used in back-pressure turbine to generate 800kW power, but there is still 5t/h, 4Bar(G) low pressure saturated steam released to atmosphere, that is wasting the latent heat.

Kerry® Kaishan screw steam expander working with ORC screw expander in series can achieve higher efficiency of power generation. Steam expander use the pressure difference while ORC use the latent heat in vaporization to generate power. At the first part of this project, the installed power is 400kW, and then second part is up to 1,500kW.

Power Benefits

- Output 400kW
- Annual Output $8,000 \times 400 = 3,200,000 \text{ kW}$
- Annual Production $3,200,000 \times 0.2 = 640 \text{ K US dollars}$
- Annual CO₂ discharge reduction $3,200,000 \times 0.522 = 1,670 \text{ Ton}$

* Average working hour is 8,000 hours.

* The electricity price is US\$ 0.2/KWh.

* To generate 1 kWh power discharge 0.522kg CO₂ (The Bureau of Energy of Taiwan, 2013)



KS-AMP POWER CO., LTD.

- Address : 11F., No.276, Jianguo Rd., Xindian Dist., New Taipei City 231, Taiwan
- Tel : +886-2-2910-5658
- Fax : +886-2-2910-5668
- Email: sales@ks-app.com

- Steam Screw Expander Generator
- ORC Screw Expander Generator
- Geothermal and Biomass
- Mini Combine Heat and Power
- Waste Heat Recovery

Reseller